

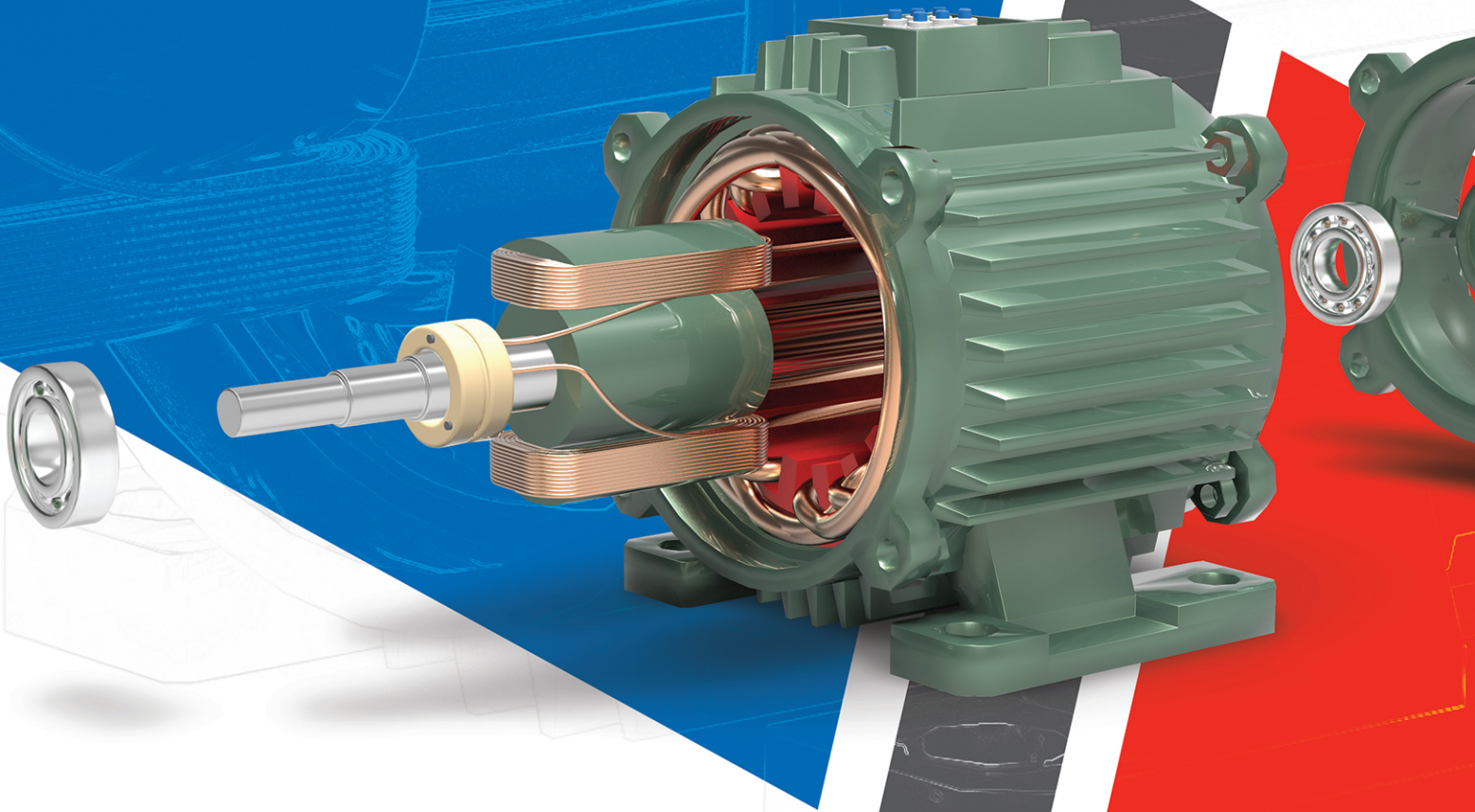

WJB BEARINGS



BALL BEARINGS **CATALOG** **FOR ELECTRIC MOTORS**

PRODUCT FEATURES AND BENEFITS

- 1 Through-hardened bearing steel with low impurity that improve bearing life.
- 2 Multiple cage material options (steel or nylon) for quiet operation and higher operating speed.
- 3 ABMA Grade 10 or better for reduced bearing vibration and noise which results in quieter operation.
- 4 Various bearing closure options to protect the bearing against contamination (dust, moisture and sand) while retaining lubricant inside the bearing for proper lubrication and longer bearing life.

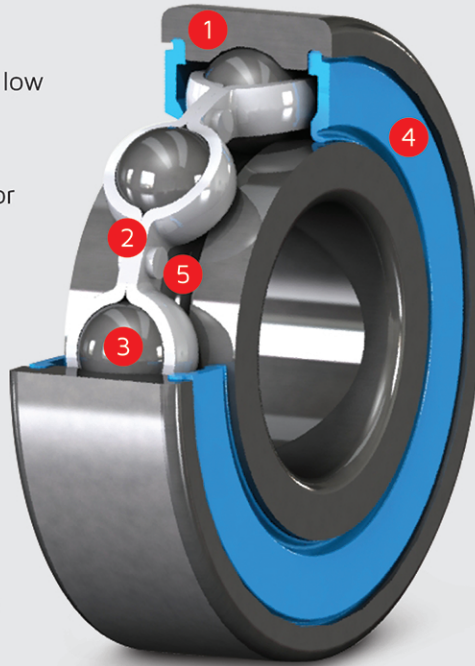

- 5 Optimized raceways design and surface finishes to reduce bearing vibration and noise for a quiet, low running friction and longer bearing life.

Available with ABEC 3, 5 & 7 (ISO P6, P5 & P2) class and special design configuration to meet your specific application requirements.

Available with premium lubricants such as Mobil Polyrex EM, Nye Rheolube 374C, Beacon 325, etc. for applications that required the bearing to operate at wide temperature range, low running noise, superior water washout resistant, and low running torque.

TYPE OF CAGE

Various inner ring groove with seals and shields

STEEL CAGE

- Readily available
- Standard cage for electric motor bearing
- Riveted or crimped for miniature bearing
- Wide range of operating temperature

NYLON CAGE

- Readily available
- Lower operating noise than steel cage
- Maximum operating temperature of 120°C

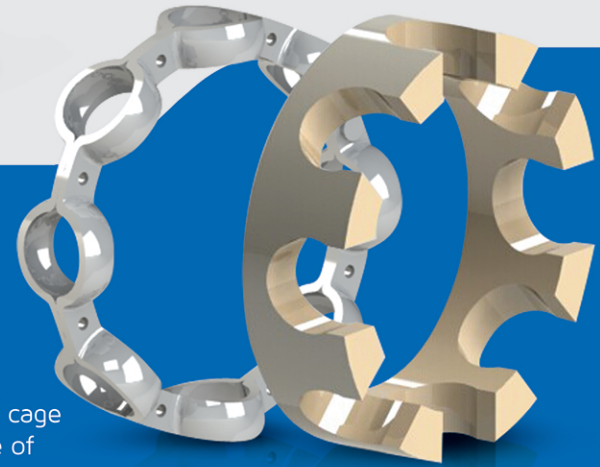

STEEL CAGE

NYLON CAGE

SEAL MATERIAL OFFERING

	NBR	ACM	FKM
WJB Seal Code	-	P	V
Continuous Max Temperature	+100 C	+150 C	+190 C
Peak Operating Temperature	+130 C	+180 C	+230 C
Low Operating Temperature	-30 C	-20 C	-15 C
Grease Resistance	GOOD	GOOD	VERY GOOD
Mineral Oil Resistance	GOOD	VERY GOOD	EXCELLENT
Wear Resistance	GOOD	POOR	GOOD
Relative Seal Cost Index	1X	2X	3X

TYPE OF SEAL CONTACT

Various seal contact

Depending on the application requirements such as speed, environment and friction requirement, a specific type of seal is selected to protect the bearing from contamination (dust and moisture) and reduce lubricant migration while keeping the bearing friction at a desired level.



Non-Contact



Light-Contact



Standard-Contact

TYPE OF INNER RING GROOVE

Various inner ring grooves with seals and shields

Where the inner ring face width is sufficient for the grooves, a "T" or "V" shape groove is machined on the OD (shoulders) of the inner ring to protect the seal contact lip and improve sealing performance.

The groove typically creates a difficult entry path for contaminants and inhibits the migration of the lubricant.

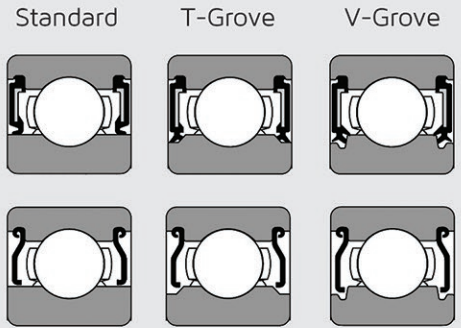

LUBRICATION (GREASES)

Selecting the suitable grease for the application can be critical which leads to either the bearings success or failure. WJB electric motor bearings are stocked with electric motor quality grease (Mobil PolyrexEM) or we can select grease based on the application requirements.

Grease	Application Use
Mobil Polyrex EM	WJB standard grease
Mobil Beacon 325	Low temperature
Kyodo Yushi Multemp SRL	Miniature, higher speed
Chevron FM ALC EP2	Food grade (FDA Approved)
Kyodo Yushi Multemp SB-M	Miniature, higher temperature
Nyogel 75xG	Electrically conductive grease

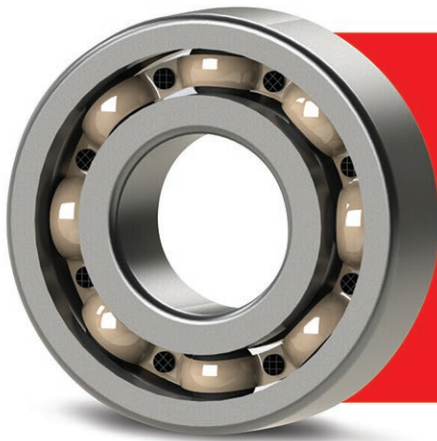

CERAMIC (SILICON NITRIDE) BALLS

In an application where the bearing is exposed to stray electric current or operated at very high speeds, hybrid ball bearings are an alternative option. Applications include variable speed electric motors with high conductivity and generators.

Ceramic ball bearing can also operate for a longer period without lubrication compared to steel ball bearing.

CONTROLLING BALL BEARING VIBRATIONS AND NOISE FOR ELECTRIC MOTOR APPLICATION

In electric motor applications, bearings with lower noise level and vibration are preferred. To achieve low noise and low vibration in the bearing, WJB controls all necessary production processes to yield a bearing with low imperfections, high precision and accurate raceway surface finishes. WJB's special designation for bearings that meet all these strict requirements is Electric Motor Quality (EMQ).

All WJB bearings that are classified as EMQ bearings are 100% noise tested on state-of-the-art bearing vibration testers (Anderson in fig. 1) to meet OEM bearing noise requirements. The bearing vibration (noise) tester measures minute vibrations from bearing imperfections and displays the bearings vibration levels over three frequency ranges (low, medium and high) as well as amplified audibly to aid the inspector during inspection.

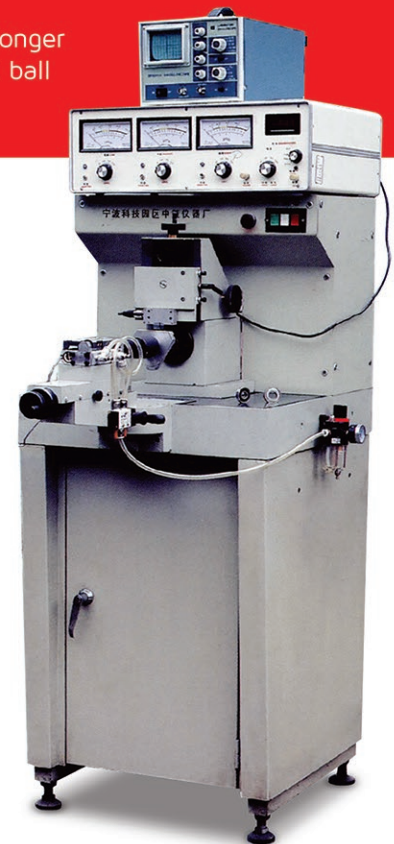
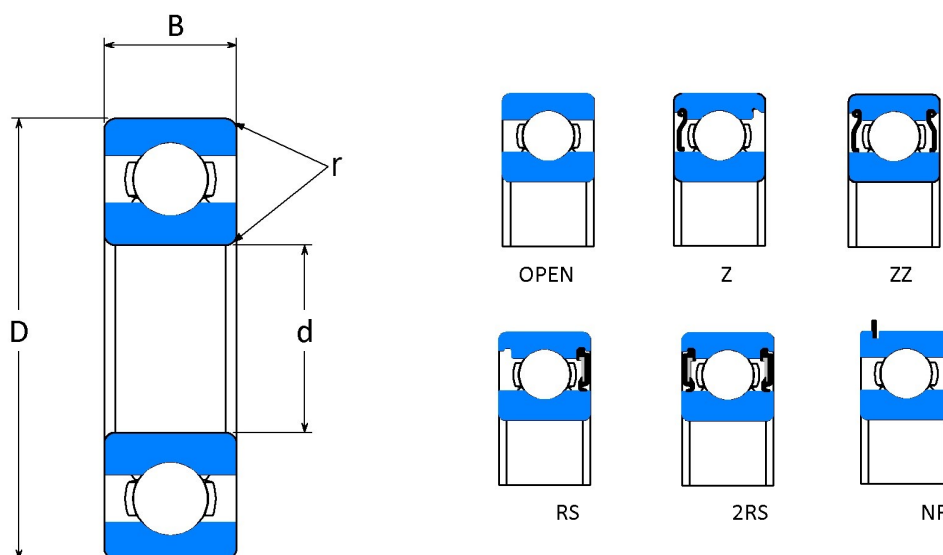

Figure 1: Standard bearing noise tester for electric motor bearings

Electric Motor Quality (EMQ) Ball Bearing



WJB Bearing No.	Bore d		Outer Diameter D		Width B		Radius r*		Basic Loading N		Weight (ref) kg	Limiting Speed of Open Bearing (RPM)	
	mm	inch	mm	inch	mm	inch	mm	inch	Dynamic Co	Static Cor		Oil	Grease
6800	10	0.3937	19	0.7480	5	0.1969	0.5	0.020	1,824	925	0.005	38,000	32,000
6900	10	0.3937	22	0.8661	6	0.2362	0.5	0.020	2,691	1,268	0.009	36,000	30,000
6000	10	0.3937	26	1.0236	8	0.3150	0.3	0.012	4,582	1,957	0.019	34,000	29,000
6200	10	0.3937	30	1.1811	9	0.3543	0.6	0.024	5,115	2,402	0.032	30,000	25,000
6300	10	0.3937	35	1.3780	11	0.4331	0.6	0.024	8,185	3,492	0.053	27,000	23,000
6801	12	0.4724	21	0.8268	5	0.1969	0.5	0.020	1,824	925	0.005	35,000	29,000
6901	12	0.4724	24	0.9449	6	0.2362	0.5	0.020	2,691	1,268	0.009	32,000	27,000
6001	12	0.4724	28	1.1024	8	0.3150	0.3	0.012	5,115	2,402	0.022	30,000	26,000
6201	12	0.4724	32	1.2598	10	0.3937	0.6	0.024	6,094	2,736	0.037	26,000	22,000
6301	12	0.4724	37	1.4567	12	0.4724	1.0	0.039	9,697	4,181	0.060	24,000	20,000
6201-8	12.7	0.5000	32	1.2598	10	0.3937	0.6	0.024	6,094	2,736	0.037	26,000	22,000
6202-8	12.7	0.5000	35	1.3780	11	0.4331	0.6	0.024	7,740	3,581	0.045	26,000	20,000
6203-8	12.7	0.5000	40	1.5748	12	0.4724	0.6	0.024	9,608	4,582	0.070	21,000	18,000
6201-13	13	0.5118	32	1.2598	10	0.3937	0.6	0.024	6,094	2,736	0.037	26,000	22,000
6802	15	0.5906	24	0.9449	5	0.1969	0.5	0.020	2,068	1,259	0.007	31,000	26,000
6902	15	0.5906	28	1.1024	7	0.2756	0.5	0.020	4,092	2,046	0.016	28,000	24,000
6002	15	0.5906	32	1.2598	9	0.3543	0.3	0.012	5,605	2,825	0.030	26,000	22,000
6202	15	0.5906	35	1.3780	11	0.4331	0.6	0.024	7,740	3,581	0.045	26,000	20,000
6203-15	15	0.5906	40	1.5748	12	0.4724	0.6	0.024	9,608	4,582	0.067	21,000	18,000
6302	15	0.5906	42	1.6535	13	0.5118	1.0	0.039	11,432	5,427	0.082	21,000	17,000
6202-10	15.875	0.6250	35	1.3780	11	0.4331	0.6	0.024	7,740	3,581	0.041	26,000	20,000
6203-10	15.875	0.6250	40	1.5748	12	0.4724	0.6	0.024	9,608	4,582	0.068	21,000	18,000

* Maximum fillet which corner radius of bearing will clear.

Electric Motor Quality (EMQ) Ball Bearing

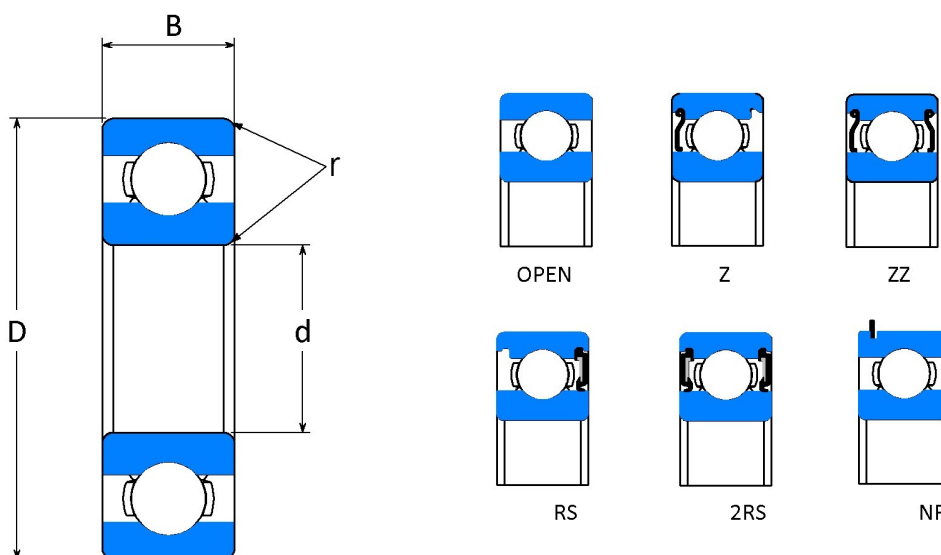

WJB Bearing No.	Bore d		Outer Diameter D		Width B		Radius r*		Basic Loading N		Weight (ref) kg	Limiting Speed of Open Bearing (RPM)	
	mm	inch	mm	inch	mm	inch	mm	inch	Dynamic Co	Static Cor		Oil	Grease
6202-16	16	0.6299	35	1.3780	11	0.4331	0.6	0.024	7,740	3,581	0.041	26,000	20,000
6203-16	16	0.6299	40	1.5748	12	0.4724	0.6	0.024	9,608	4,582	0.068	21,000	18,000
6803	17	0.6693	26	1.0236	5	0.1969	0.5	0.020	2,802	1,713	0.008	28,000	24,000
6903	17	0.6693	30	1.1811	7	0.2756	0.5	0.020	4,671	2,580	0.018	26,000	22,000
6003	17	0.6693	35	1.3780	10	0.3937	0.3	0.012	6,806	3,358	0.039	24,000	20,000
6203	17	0.6693	40	1.5748	12	0.4724	0.6	0.024	9,608	4,582	0.065	21,000	18,000
6303	17	0.6693	47	1.8504	14	0.5512	1.0	0.039	13,567	6,539	0.115	19,000	16,000
6403	17	0.6693	62	2.4409	17	0.6693	1.0	0.039	22,686	10,765	0.272	16,000	14,000
6203-12	19.05	0.7500	40	1.5748	12	0.4724	0.6	0.024	9,608	4,582	0.064	21,000	18,000
6204-12	19.05	0.7500	47	1.8504	14	0.5512	1.0	0.039	12,855	6,672	0.107	18,000	16,000
6804	20	0.7874	32	1.2598	7	0.2756	0.5	0.020	1,824	925	0.019	25,000	21,000
6904	20	0.7874	37	1.4567	9	0.3543	0.5	0.020	2,691	1,268	0.036	23,000	19,000
6004	20	0.7874	42	1.6535	12	0.4724	0.6	0.024	3,523	1,810	0.069	21,000	18,000
6204	20	0.7874	47	1.8504	14	0.5512	1.0	0.039	5,115	2,402	0.106	18,000	16,000
6304	20	0.7874	52	2.0472	15	0.5906	1.1	0.043	8,185	3,492	0.144	17,000	14,000
6404	20	0.7874	72	2.8346	19	0.7480	1.0	0.039	2,691	1,268	0.408	14,000	12,000
60/22	22	0.8661	44	1.7323	12	0.4724	0.6	0.024	9,386	5,115	0.074	20,000	17,000
62/22	22	0.8661	50	1.9685	14	0.5512	1.0	0.039	12,900	6,806	0.117	17,000	14,000
63/22	22	0.8661	56	2.2047	16	0.6299	1.1	0.043	18,238	9,252	0.232	15,000	13,000
6204-14	22.225	0.8750	47	1.8504	14	0.5512	1.0	0.039	12,855	6,672	0.104	18,000	16,000

* Maximum fillet which corner radius of bearing will clear.

Electric Motor Quality (EMQ) Ball Bearing

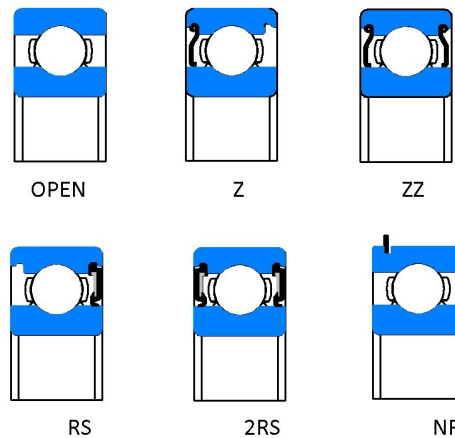
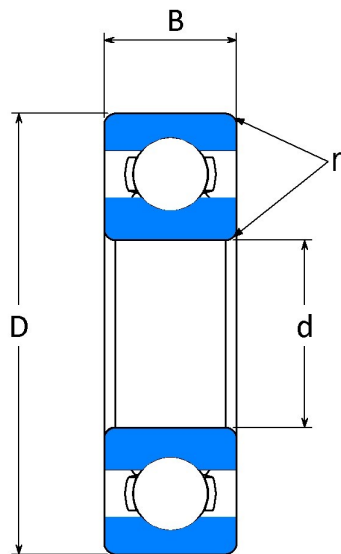

WJB Bearing No.	Bore d		Outer Diameter D		Width B		Radius r*		Basic Loading N		Weight (ref) kg	Limiting Speed of Open Bearing (RPM)	
	mm	inch	mm	inch	mm	inch	mm	inch	Dynamic Co	Static Cor		Oil	Grease
6805	25	0.9843	37	1.4567	7	0.2756	0.5	0.020	4,293	2,958	0.024	21,000	18,000
6905	25	0.9843	42	1.6535	9	0.3543	0.5	0.020	7,028	4,537	0.042	19,000	16,000
6005	25	0.9843	47	1.8504	12	0.4724	0.6	0.024	10,053	5,872	0.080	18,000	15,000
6205	25	0.9843	52	2.0472	15	0.5906	1.0	0.039	14,012	7,873	0.128	15,000	13,000
6305	25	0.9843	62	2.4409	17	0.6693	1.1	0.043	21,129	10,943	0.232	14,000	12,000
6405	25	0.9843	80	3.1496	21	0.8268	1.5	0.059	21,129	10,943	0.540	12,000	10,000
6205-16	25.4	1.0000	52	2.0472	15	0.5906	1.0	0.039	14,012	7,873	0.127	15,000	13,000
60/28	28	1.1024	52	2.0472	12	0.4724	0.6	0.024	12,455	7,384	0.098	16,000	14,000
62/28	28	1.1024	58	2.2835	16	0.6299	1.0	0.039	17,793	9,742	0.171	14,000	12,000
63/28	28	1.1024	68	2.6772	18	0.7087	1.1	0.043	26,689	14,012	0.287	13,000	11,000
6806	30	1.1811	42	1.6535	7	0.2756	0.5	0.020	4,715	3,625	0.025	18,000	15,000
6906	30	1.1811	47	1.8504	9	0.3543	0.5	0.020	7,251	5,026	0.048	17,000	14,000
6006	30	1.1811	55	2.1654	13	0.5118	1.0	0.039	13,200	8,300	0.116	15,000	13,000
6206	30	1.1811	62	2.4409	16	0.6299	1.0	0.039	19,572	11,298	0.199	13,000	11,000
6306	30	1.1811	72	2.8346	19	0.7480	1.1	0.043	29,803	16,903	0.346	12,000	10,000
6406	30	1.1811	90	3.5433	23	0.9055	1.5	0.059	43,370	23,798	0.721	10,000	8,800
60/32	32	1.2598	58	2.2835	13	0.5118	1.0	0.039	15,124	9,119	0.129	15,000	12,000
62/32	32	1.2598	65	2.5591	17	0.6693	1.0	0.039	20,573	11,565	0.226	12,000	11,000
63/32	32	1.2598	75	2.9528	20	0.7874	1.1	0.043	102,309	71,172	0.382	11,000	9,500

* Maximum fillet which corner radius of bearing will clear.

Electric Motor Quality (EMQ) Ball Bearing

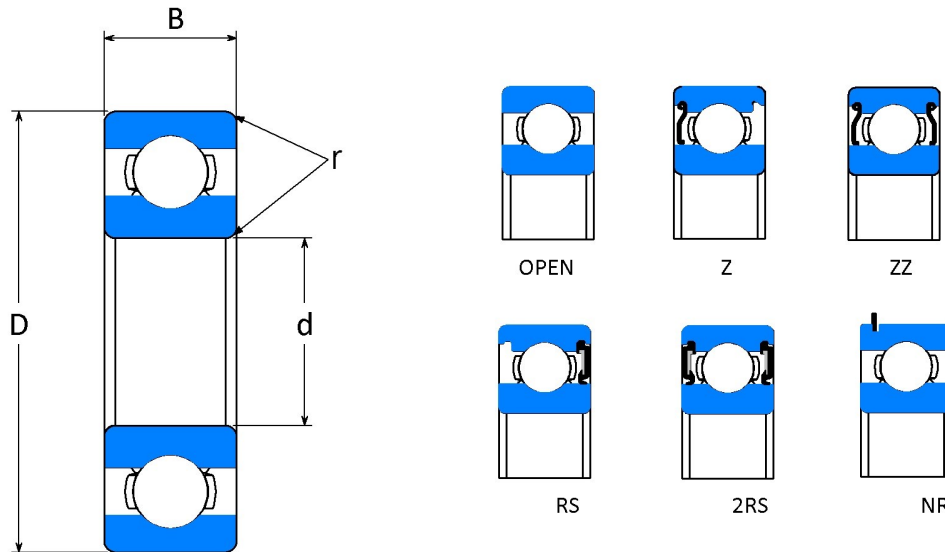

WJB Bearing No.	Bore d		Outer Diameter D		Width B		Radius r*		Basic Loading N		Weight (ref) kg	Limiting Speed of Open Bearing (RPM)	
	mm	inch	mm	inch	mm	inch	mm	inch	Dynamic Co	Static Cor		Oil	Grease
6807	35	1.3780	47	1.8504	7	0.2756	0.5	0.020	4,893	4,026	0.029	16,000	13,000
6907	35	1.3780	55	2.1654	10	0.3937	1.0	0.039	11,165	7,429	0.074	15,000	12,000
6007	35	1.3780	62	2.4409	14	0.5512	1.0	0.039	16,014	10,275	0.155	14,000	12,000
6207	35	1.3780	72	2.8346	17	0.6693	1.1	0.043	25,577	15,346	0.288	11,000	9,300
6307	35	1.3780	80	3.1496	21	0.8268	1.5	0.059	33,362	19,127	0.458	10,000	8,800
6407	35	1.3780	100	3.9370	25	0.9843	1.5	0.059	55,158	31,138	0.934	9,100	7,800
6808	40	1.5748	52	2.0472	7	0.2756	0.5	0.020	5,071	4,381	0.033	14,000	12,000
6908	40	1.5748	62	2.4409	12	0.4724	1.0	0.039	13,612	9,964	0.110	13,000	11,000
6008	40	1.5748	68	2.6772	15	0.5906	1.0	0.039	16,681	11,521	0.192	12,000	10,000
6208	40	1.5748	80	3.1496	18	0.7087	1.1	0.043	29,136	17,793	0.366	10,000	8,700
6308	40	1.5748	90	3.5433	23	0.9055	1.5	0.059	40,701	24,020	0.635	9,200	7,800
6408	40	1.5748	110	4.3307	27	1.0630	2.0	0.079	63,610	36,475	1.22	8,200	7,000
6809	45	1.7717	58	2.2835	7	0.2756	0.5	0.020	6,312	5,649	0.040	12,000	11,000
6909	45	1.7717	68	2.6772	12	0.4724	1.0	0.039	15,124	11,254	0.128	12,000	9,800
6009	45	1.7717	75	2.9528	16	0.6299	1.0	0.039	20,907	15,124	0.245	11,000	9,200
6209	45	1.7717	85	3.3465	19	0.7480	1.1	0.043	32,694	20,462	0.407	9,200	7,800
6309	45	1.7717	100	3.9370	25	0.9843	1.5	0.059	52,934	32,027	0.835	8,200	7,000
6409	45	1.7717	120	4.7244	29	1.1417	2.0	0.079	76,954	44,927	1.55	7,400	6,300

* Maximum fillet which corner radius of bearing will clear.

Electric Motor Quality (EMQ) Ball Bearing

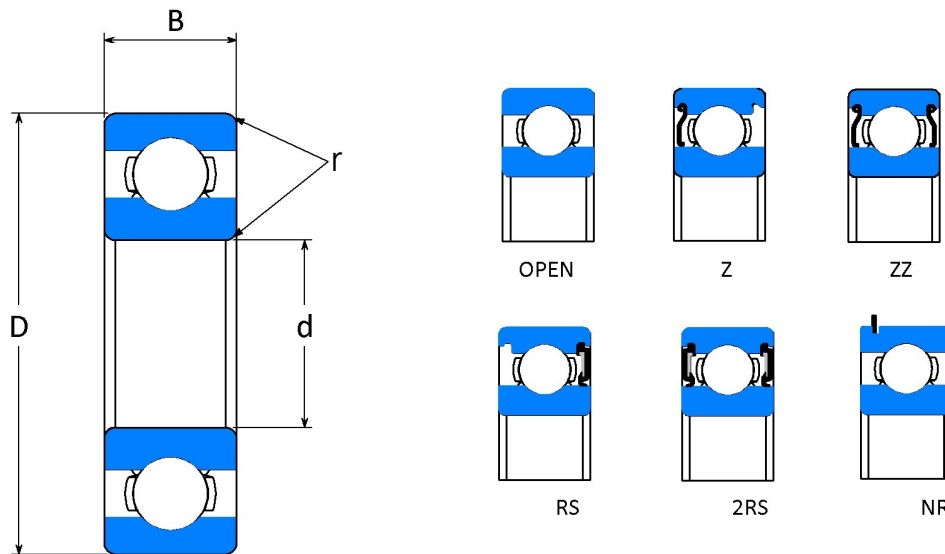

WJB Bearing No.	Bore d		Outer Diameter D		Width B		Radius r*		Basic Loading N		Weight (ref) kg	Limiting Speed of Open Bearing (RPM)	
	mm	inch	mm	inch	mm	inch	mm	inch	Dynamic Co	Static Cor		Oil	Grease
6810	50	1.9685	65	2.5591	7	0.2756	0.5	0.020	6,583	6,094	0.052	11,000	9,600
6910	50	1.9685	72	2.8346	12	0.4724	1.0	0.039	15,569	12,233	0.132	11,000	8,900
6010	50	1.9685	80	3.1496	16	0.6299	1.0	0.039	21,796	16,681	0.261	9,800	8,400
6210	50	1.9685	90	3.5433	20	0.7874	1.1	0.043	35,141	23,131	0.463	8,300	7,100
6310	50	1.9685	110	4.3307	27	1.0630	2.0	0.079	61,830	38,255	1.07	7,500	6,400
6410	50	1.9685	130	5.1181	31	1.2205	2.0	0.079	83,182	49,375	1.91	6,700	5,700
6811	55	2.1654	72	2.8346	9	0.3543	0.5	0.020	8,807	8,096	0.083	10,000	8,700
6911	55	2.1654	80	3.1496	13	0.5118	1.5	0.059	16,014	13,256	0.180	9,600	8,200
6011	55	2.1654	90	3.5433	18	0.7087	1.1	0.043	28,246	21,351	0.385	9,000	7,700
6211	55	2.1654	100	3.9370	21	0.8268	1.5	0.059	43,370	29,136	0.608	7,600	6,400
6311	55	2.1654	120	4.7244	29	1.1417	2.0	0.079	71,616	44,927	1.37	6,800	5,800
6411	55	2.1654	140	5.5118	33	1.2992	1.0	0.039	88,964	53,823	2.33	6,100	5,200
6812	60	2.3622	78	3.0709	10	0.3937	0.5	0.020	11,476	10,587	0.106	9,400	8,000
6912	60	2.3622	85	3.3465	13	0.5118	1.5	0.059	16,458	14,234	0.193	8,900	7,600
6012	60	2.3622	95	3.7402	18	0.7087	1.1	0.043	29,358	23,131	0.415	8,300	7,000
6212	60	2.3622	110	4.3307	22	0.8661	1.5	0.059	52,489	36,253	0.785	7,000	6,000
6312	60	2.3622	130	5.1181	31	1.2205	2.1	0.083	81,847	52,044	1.70	6,300	5,400
6412	60	2.3622	150	5.9055	35	1.3780	2.0	0.079	101,864	64,054	2.82	5,700	4,800

* Maximum fillet which corner radius of bearing will clear.

Electric Motor Quality (EMQ) Ball Bearing

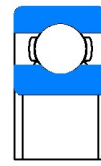
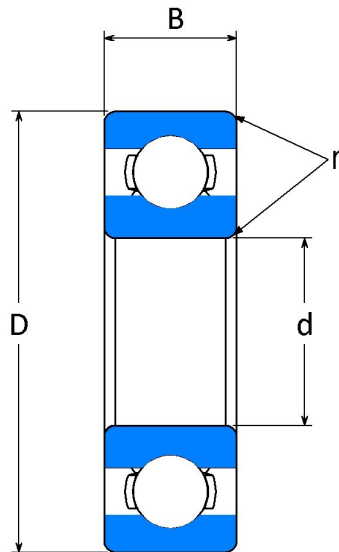

OPEN

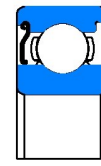

Z

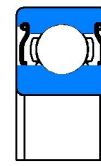

ZZ

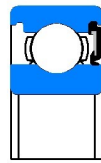

RS

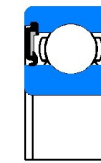

2RS

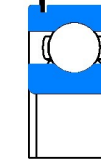

NR

WJB Bearing No.	Bore d		Outer Diameter D		Width B		Radius r*		Basic Loading N		Weight (ref) kg	Limiting Speed of Open Bearing (RPM)	
	mm	inch	mm	inch	mm	inch	mm	inch	Dynamic Co	Static Cor		Oil	Grease
6813	65	2.5591	85	3.3465	10	0.3937	1.0	0.039	11,610	11,032	0.127	8,700	7,400
6913	65	2.5591	90	3.5433	13	0.5118	1.5	0.059	17,304	16,058	0.206	8,200	7,000
6013	65	2.5591	100	3.9370	18	0.7087	1.1	0.043	30,470	25,132	0.435	7,700	6,500
6213	65	2.5591	120	4.7244	23	0.9055	1.5	0.059	57,382	40,034	0.989	6,500	5,500
6313	65	2.5591	140	5.5118	33	1.2992	2.1	0.083	92,523	59,606	2.08	5,800	4,900
6413	65	2.5591	160	6.2992	37	1.4567	2.0	0.079	110,761	72,061	3.37	5,200	4,400
6814	70	2.7559	90	3.5433	10	0.3937	1.0	0.039	12,099	11,921	0.137	8,100	6,900
6914	70	2.7559	100	3.9370	16	0.6299	1.5	0.059	23,798	21,129	0.334	7,700	6,500
6014	70	2.7559	110	4.3307	20	0.7874	1.1	0.043	38,032	30,915	0.603	7,100	6,100
6214	70	2.7559	125	4.9213	24	0.9449	1.5	0.059	62,275	44,037	1.07	6,000	5,100
6314	70	2.7559	150	5.9055	35	1.3780	2.1	0.083	104,088	68,058	2.52	5,400	4,600
6414	70	2.7559	180	7.0866	42	1.6535	2.5	0.098	128,109	89,409	4.99	4,800	4,100
6815	75	2.9528	95	3.7402	10	0.3937	1.0	0.039	12,544	12,855	0.145	7,600	6,400
6915	75	2.9528	105	4.1339	16	0.6299	1.5	0.059	24,465	22,686	0.353	7,400	6,100
6015	75	2.9528	115	4.5276	20	0.7874	1.1	0.043	39,589	33,584	0.640	6,700	5,700
6215	75	2.9528	130	5.1181	25	0.9843	1.5	0.059	66,279	49,375	1.18	5,600	4,800
6315	75	2.9528	160	6.2992	37	1.4567	2.1	0.083	113,430	77,399	3.02	5,000	4,300
6415	75	2.9528	190	7.4803	45	1.7717	2.5	0.098	137,895	99,195	5.94	4,500	3,800

* Maximum fillet which corner radius of bearing will clear.

Electric Motor Quality (EMQ) Ball Bearing

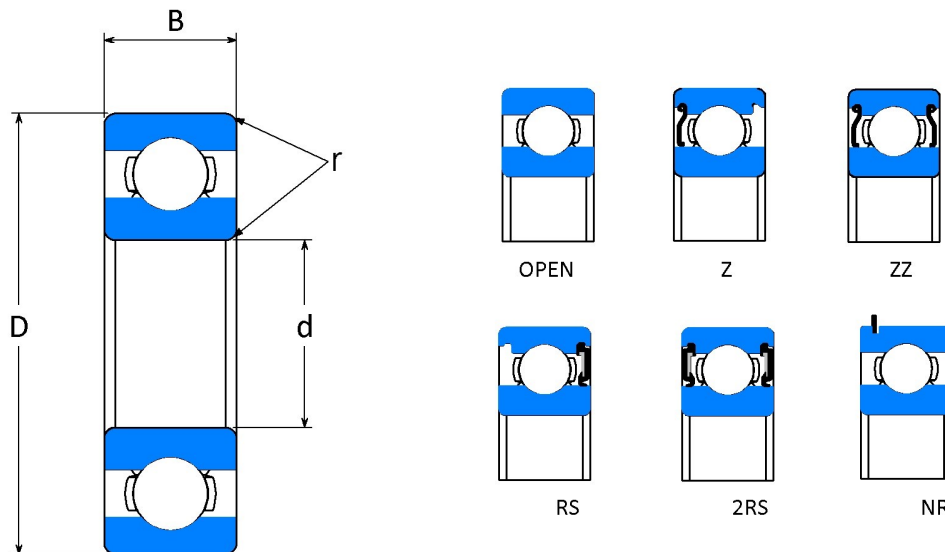

WJB Bearing No.	Bore d		Outer Diameter D		Width B		Radius r*		Basic Loading N		Weight (ref) kg	Limiting Speed of Open Bearing (RPM)	
	mm	inch	mm	inch	mm	inch	mm	inch	Dynamic Co	Static Cor		Oil	Grease
6816	80	3.1496	100	3.9370	10	0.3937	1.0	0.039	12,677	13,300	0.153	7,100	6,000
6916	80	3.1496	110	4.3307	16	0.6299	2.0	0.079	24,910	24,020	0.373	6,700	5,700
6016	80	3.1496	125	4.9213	22	0.8661	1.1	0.043	47,596	39,812	0.848	6,200	5,300
6216	80	3.1496	140	5.5118	26	1.0236	2.0	0.079	72,506	52,934	1.40	5,300	4,500
6316	80	3.1496	170	6.6929	39	1.5354	2.1	0.083	122,771	86,740	3.59	4,700	4,000
6416	80	3.1496	200	7.8740	48	1.8898	2.5	0.098	164,584	125,440	6.94	4,200	3,500
6817	85	3.3465	110	4.3307	13	0.5118	1.5	0.059	18,683	18,905	0.269	6,700	5,700
6917	85	3.3465	120	4.7244	18	0.7087	2.0	0.079	32,027	29,581	0.535	6,300	5,400
6017	85	3.3465	130	5.1181	22	0.8661	1.1	0.043	49,375	43,148	0.889	5,900	5,000
6217	85	3.3465	150	5.9055	28	1.1024	2.0	0.079	83,182	63,610	1.79	5,000	4,200
6317	85	3.3465	180	7.0866	41	1.6142	3.0	0.118	132,557	96,971	4.23	4,500	3,800
6417	85	3.3465	210	8.2677	52	2.0472	3.0	0.118	164,584	127,664	8.53	4,000	3,400
6818	90	3.5433	115	4.5276	13	0.5118	1.5	0.059	18,905	19,795	0.284	6,300	5,400
6918	90	3.5433	125	4.9213	18	0.7087	2.0	0.079	32,783	31,315	0.553	6,000	5,100
6018	90	3.5433	140	5.5118	24	0.9449	1.5	0.059	58,272	49,820	1.16	5,600	4,700
6218	90	3.5433	160	6.2992	30	1.1811	2.0	0.079	96,082	71,616	2.15	4,700	4,000
6318	90	3.5433	190	7.4803	43	1.6929	3.0	0.118	142,343	107,202	4.90	4,200	3,600
6418	90	3.5433	225	8.8583	54	2.1260	3.0	0.118	184,601	157,912	11.52	3,800	3,200

* Maximum fillet which corner radius of bearing will clear.

Electric Motor Quality (EMQ) Ball Bearing

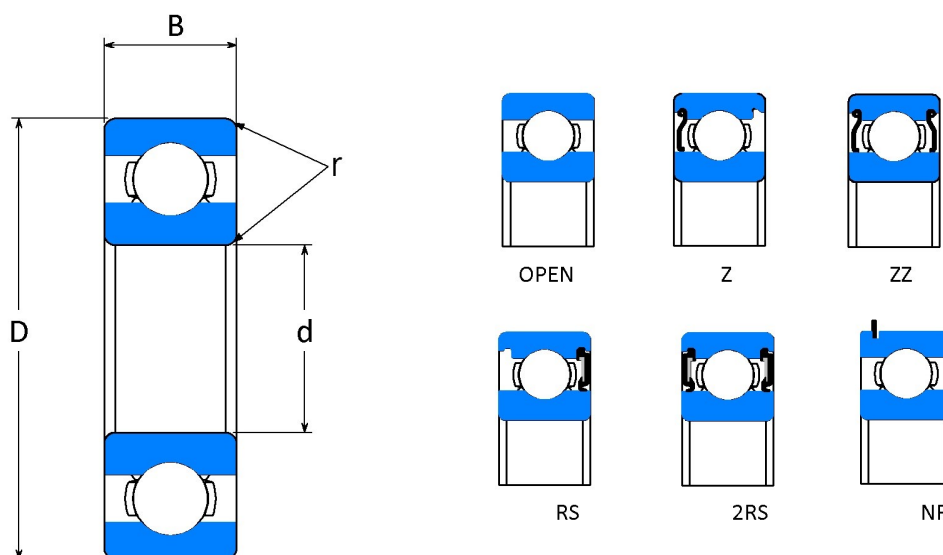

WJB Bearing No.	Bore d		Outer Diameter D		Width B		Radius r*		Basic Loading N		Weight (ref) kg	Limiting Speed of Open Bearing (RPM)	
	mm	inch	mm	inch	mm	inch	mm	inch	Dynamic Co	Static Cor		Oil	Grease
6819	95	3.7402	120	4.7244	13	0.5118	1.5	0.059	19,350	20,684	0.299	5,900	5,000
6919	95	3.7402	130	5.1181	18	0.7087	2.0	0.079	33,584	33,584	0.581	5,700	4,800
6019	95	3.7402	145	5.7087	24	0.9449	1.5	0.059	60,496	53,823	1.21	5,300	4,500
6219	95	3.7402	170	6.6929	32	1.2598	2.1	0.083	108,981	81,847	2.62	4,400	3,700
6319	95	3.7402	200	7.8740	45	1.7717	3.0	0.118	153,464	118,323	5.67	3,900	3,300
6820	100	3.9370	125	4.9213	13	0.5118	1.5	0.059	19,572	21,129	0.303	5,600	4,800
6920	100	3.9370	140	5.5118	20	0.7874	2.0	0.079	41,146	39,589	0.785	5,300	4,500
6220	100	3.9370	180	7.0866	34	1.3386	2.1	0.083	122,326	92,968	3.14	4,200	3,500
6320	100	3.9370	215	8.4646	47	1.8504	3.0	0.118	173,481	140,119	6.99	3,700	3,200
6021	105	4.1339	160	6.2992	26	1.0236	2.0	0.079	72,506	65,834	1.59	4,700	4,000
6221	105	4.1339	190	7.4803	36	1.4173	2.1	0.083	133,002	104,533	3.70	4,000	3,400
6321	105	4.1339	225	8.8583	49	1.9291	3.0	0.118	184,601	153,464	8.03	3,600	3,000
6022	110	4.3307	170	6.6929	28	1.1024	2.0	0.079	81,847	72,951	1.96	4,500	3,800
6222	110	4.3307	200	7.8740	38	1.4961	2.1	0.083	144,567	116,988	4.36	3,800	3,200
6322	110	4.3307	240	9.4488	50	1.9685	3.0	0.118	177,929	180,153	9.53	3,400	2,900
6024	120	4.7244	180	7.0866	28	1.1024	2.0	0.079	84,961	79,178	2.07	4,100	3,500
6224	120	4.7244	215	8.4646	40	1.5748	2.1	0.083	155,688	131,223	5.17	3,400	2,900
6324	120	4.7244	260	10.2362	55	2.1654	3.0	0.118	206,842	184,601	12.38	3,100	2,600
6026**	130	5.1181	200	7.8740	33	1.2992	2.0	0.079	106,312	100,975	3.16	3,800	3,200
6226**	130	5.1181	230	9.0551	40	1.5748	3.0	0.118	166,808	146,791	5.81	3,100	2,700
6326**	130	5.1181	280	11.0236	58	2.2835	4.0	0.157	229,083	213,515	15.10	2,800	2,400

* Maximum fillet which corner radius of bearing will clear.

** Manufacture to order only

Electric Motor Quality (EMQ) Ball Bearing

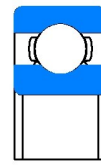
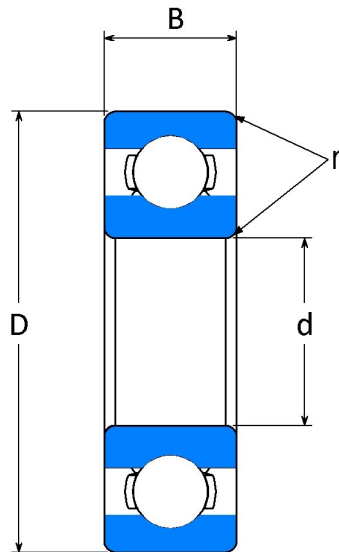

OPEN

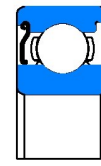

Z

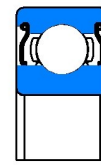

ZZ

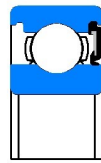

RS

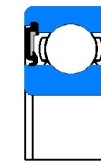

2RS

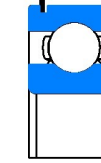

NR

WJB Bearing No.	Bore d		Outer Diameter D		Width B		Radius r*		Basic Loading N		Weight (ref) kg	Limiting Speed of Open Bearing (RPM)	
	mm	inch	mm	inch	mm	inch	mm	inch	Dynamic Co	Static Cor		Oil	Grease
6028**	140	5.5118	210	8.2677	33	1.2992	2.0	0.079	109,871	108,537	3.35	3,500	3,000
6228**	140	5.5118	250	9.8425	42	1.6535	3.0	0.118	166,808	149,015	7.48	2,900	2,500
6328**	140	5.5118	300	11.8110	62	2.4409	4.0	0.157	253,549	246,876	18.51	2,600	2,200
6030**	150	5.9055	225	8.8583	35	1.3780	2.0	0.079	125,885	125,885	4.08	3,200	2,800
6230**	150	5.9055	270	10.6299	45	1.7717	3.0	0.118	175,705	166,808	9.39	2,700	2,300
6330**	150	5.9055	320	12.5984	65	2.5591	4.0	0.157	273,566	282,462	26.22	2,400	2,100
6032**	160	6.2992	240	9.4488	38	1.4961	2.0	0.079	142,343	144,567	5.03	3,000	2,600
6232**	160	6.2992	290	11.4173	48	1.8898	3.0	0.118	186,002	186,002	14.29	2,500	2,100
6034**	170	6.6929	260	10.2362	42	1.6535	2.0	0.079	169,032	171,257	7.94	2,800	2,400
6234**	170	6.6929	310	12.2047	52	2.0472	4.0	0.157	211,998	223,999	17.51	2,400	2,000
6036**	180	7.0866	280	11.0236	46	1.8110	2.0	0.079	189,049	197,946	10.30	2,700	2,300
6236**	180	7.0866	320	12.5984	52	2.0472	4.0	0.157	226,997	241,000	18.28	2,200	1,900
6038**	190	7.4803	290	11.4173	46	1.8110	2.0	0.079	195,722	215,739	10.80	2,500	2,100
6238**	190	7.4803	340	13.3858	55	2.1654	4.0	0.157	254,999	281,999	23.00	2,100	1,800
6040**	200	7.8740	310	12.2047	51	2.0079	2.1	0.083	217,963	242,428	13.88	2,400	2,000
6240**	200	7.8740	360	14.1732	58	2.2835	4.0	0.157	268,997	309,997	28.21	1,800	1,500

* Maximum fillet which corner radius of bearing will clear.

** Manufacture to order only



WJB Headquarters

535 Brea Canyon Road
City of Industry, CA 91789
Phone: 909.598.6238

Fax: 909.598.7939
Toll Free: 800.572.1688
Email: info@wjbgroup.com

WJB North Carolina

725 Shea road
Newton, NC 28658
Phone: 828.353.0091

www.wjbgroup.com

WJB is an expert in the design, manufacturing, and supply of a wide range of bearing products. Our manufacturing facilities have been awarded ISO9001 and TS16949 certifications. WJB has a worldwide network of manufacturing, research, and development facilities. We are able to develop and launch fully customized bearing solutions to complex mechanical systems using ROMAX and COBRA analysis software. Around the world, companies in the industrial and automotive industry have improved their performance by turning to WJB.

